



electronic powersolutions

# CFM50S SERIES 50 WATT OPEN FRAME AC-DC MODULES

## Features

- Universal Input Range 90~264Vac
- High Efficiency up to 89%
- 2"x 3" Open Frame Compact Size
- Class I and Class II
- No Load Input Power < 0.15W
- Approval IEC/EN/UL 62368-1
- Meets IEC/EN 60335-1
- Approval EN 55032 Class B and CISPR/FCC Class B
- Operating Altitude 5000m
- Continuous Short Circuit Protection
- Over Voltage Protection

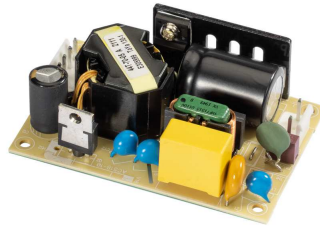

MODEL NUMBER	OUTPUT VOLTAGE	OUTPUT CURRENT	VOLTAGE ACCURACY NOTE1	RIPPLE& NOISE NOTE2	LINE REGULATION NOTE3	LOAD REGULATION NOTE4	%EFF. (Typ.) NOTE5
CFM50S050	5 V	8.0 A	±2%	150 mV	±0.5%	±1%	85%
CFM50S120	12 V	4.17 A	±2%	120 mV	±0.5%	±1%	87%
CFM50S150	15 V	3.33 A	±1%	150 mV	±0.5%	±1%	88%
CFM50S240	24 V	2.08 A	±1%	240 mV	±0.5%	±1%	89%
CFM50S360	36 V	1.39 A	±1%	360 mV	±0.5%	±1%	89%
CFM50S480	48 V	1.04 A	±1%	480 mV	±0.5%	±1%	89%

Note:

1. Voltage accuracy is set at 100% full load.
2. Add a 0.1uF ceramic capacitor and a 10uF E.L. capacitor to output for ripple & noise measurement @20MHz BW.
3. Line regulation is measured from 90V<sub>ac</sub> to 264V<sub>ac</sub> with 100% full load.
4. Load regulation is measured from 10% to full load.
5. Typical efficiency at 230 V<sub>ac</sub> and 100% full load at 25°C.
6. Standard input and output connectors (CN1 and CN2) wafer with TAIWAN KING PIN TERMINAL PVHI series and mate with JST housing VHR series and JST SVH-41T-P1.1 series crimp terminal and output connectors wire 16AWG.

## PART NUMBER

Series	Number of Outputs	Nominal Output Voltage	Type
CFM50	O	XX	-X (Option)
CFM50	S : Single	050 : 05V 120 : 12V 150 : 15V 240 : 24V 360 : 36V 480 : 48V	None : Wafer P : PCB Mount CA : Cover

Part Number Example:

**CFM50S120:** Open Frame, 50W, Single 12V<sub>dc</sub> Output



## TECHNICAL SPECIFICATIONS

(All specifications are typical at nominal input, full load at 25°C unless otherwise noted.)

### ABSOLUTE MAXIMUM RATINGS

PARAMETER	NOTES and CONDITIONS	Device	Min.	Typ.	Max.	Units
Input Voltage	Safety approvals only to the AC input	All	90		264	V <sub>ac</sub>
				120		370
Operating Temperature	See Derating Curve	All	-30		80	°C
Storage Temperature		All	-30		85	°C
Operating Altitude	IEC/EN/UL 62368-1	All			5000	m
	Meets IEC/EN 60335-1				3000	

### INPUT CHARACTERISTICS

PARAMETER	NOTES and CONDITIONS	Device	Min.	Typ.	Max.	Units
Operating Voltage Range		All	100		240	V <sub>ac</sub>
Input Frequency Range		All	50		60	Hz
Maximum Input Current	100% Load, V <sub>in</sub> =100V <sub>ac</sub>	All			1.2	A
Leakage Current		All			0.1	mA
Inrush Current	V <sub>in</sub> =240V <sub>ac</sub> , Cold start at 25°C	All		110		A

### OUTPUT CHARACTERISTICS

PARAMETER	NOTES and CONDITIONS	Device	Min.	Typ.	Max.	Units
Output Voltage Set Point	V <sub>in</sub> =Nominal V <sub>in</sub> , I <sub>o</sub> =I <sub>o</sub> max., T <sub>c</sub> =25°C	CFM50S050	4.90	5	5.10	V <sub>dc</sub>
		CFM50S120	11.76	12	12.24	
		CFM50S150	14.85	15	15.15	
		CFM50S240	23.76	24	24.24	
		CFM50S360	35.64	36	36.36	
		CFM50S480	47.52	48	48.48	
Operating Output Current Range	V <sub>in</sub> =115V <sub>ac</sub> and 230V <sub>ac</sub> , T <sub>c</sub> =25°C	CFM50S050			8.00	A
		CFM50S120			4.17	
		CFM50S150			3.33	
		CFM50S240			2.08	
		CFM50S360			1.39	
		CFM50S480			1.04	
Holdup Time	V <sub>in</sub> =115V <sub>ac</sub>	All	8			ms
Output Voltage Regulation						
Load Regulation	10% Load to full load	All			±1.0	%
Line Regulation	V <sub>in</sub> =High Line to low line	All			±0.5	%
Over Voltage Protection	Hiccup mode (Auto recovery)	CFM50S050			10.0	V <sub>dc</sub>
		CFM50S120			16.0	
		CFM50S150			25.0	
		CFM50S240			35.0	
		CFM50S360			50.0	
		CFM50S480			63.0	
Over Current Protection	Hiccup mode (Auto recovery)	All	110		140	%
Short Circuit Protection	Hiccup mode (Auto recovery)	All				
Output Ripple and Noise	1. Add a 0.1uF ceramic capacitor and a 10uF aluminum electrolytic capacitor to output 2. Oscilloscope is 20MHz band width 3. Ambient Temperature=25°C	CFM50S050			150	mV
		CFM50S120			120	
		CFM50S150			150	
		CFM50S240			240	
		CFM50S360			360	
		CFM50S480			480	



# CFM50S Series

PARAMETER	NOTES and CONDITIONS	Device	Min.	Typ.	Max.	Units
Load Capacitance	1. $V_{in}=115V_{ac}$ and $230V_{ac}$ 2. Output is max. load 3. Ambient temperature= $25^{\circ}C$	CFM50S050			8000	uF
		CFM50S120			4200	
		CFM50S150			3400	
		CFM50S240			2087	
		CFM50S360			1440	
		CFM50S480			600	
Efficiency	1. Output is rated load 2. Ambient temperature= $25^{\circ}C$ 3. Input voltage is $230V_{ac}$	CFM50S050		85		%
		CFM50S120		87		
		CFM50S150		88		
		CFM50S240		89		
		CFM50S360		89		
		CFM50S480		89		

## ISOLATION CHARACTERISTICS

PARAMETER	NOTES and CONDITIONS	Device	Min.	Typ.	Max.	Units
Input to Output	1 minute	All			3000	$V_{ac}$
Isolation Resistance	Input to output	All	100			M $\Omega$

## FEATURE CHARACTERISTICS

PARAMETER	NOTES and CONDITIONS	Device	Min.	Typ.	Max.	Units
Switching Frequency	Pout=max. rated power	All		65		kHz

## GENERAL SPECIFICATIONS

PARAMETER	NOTES and CONDITIONS	Device	Min.	Typ.	Max.	Units
MTBF	$I_o=100\%$ ; $T_a=25^{\circ}C$ per MIL-HDBK-217F	All		1200		k hours
Humidity	Non-condensing	All			93	% RH
Shock	Meet MIL-STD-810F Table 516.5, Table 516.5-I 10ms, each axis 3 times( $\pm X$ 、 $\pm Y$ 、 $\pm Z$ axis)	All		75		g
Vibration	Meet MIL-STD-810F Table 514.5C-VIII, 15~2000Hz, X、Y、Z axis, 1 hour (each axis),. Total 3 hrs.	All		4		g
Weight		CFM50S		95		grams
		CFM50S-P		93		
		CFM50S-CA		180		
Dimensions	Open Frame (Wafer)	All	3.000x2.000x1.067 Inches (76.20x50.80x27.10 mm)			
	P (PCB Mount)		3.000x2.000x1.142 Inches (76.20x50.80x29.00 mm)			
	CA (Cover)		3.598x2.520x1.358 inches (91.40x64.00x34.50 mm)			
<b>Safety</b>	Class I, Class II, IEC/EN/UL62368-1 Safety approvals do not apply to the covered version only to the open frame versions					
<b>EMC Emission</b>	EN55032:2015+AC:2016, 47 CFR FCC Part 15 Subpart B EN61000-3-2:2019, EN61000-3-3:2013					Class B
Conducted Disturbance	EN55032, 47 CFR FCC Part 15					Class B
Radiated Disturbance	EN55032, 47 CFR FCC Part 15					Class B
Harmonic Current Emissions	EN 61000-3-2:2019					
Voltage Fluctuations & Flicker	EN 61000-3-3:2013					
<b>EMC Immunity</b>	EN55035:2017					
Electrostatic Discharge (ESD)	IEC 61000-4-2:2008, Air Discharge: $\pm 8kV$ , Contact Discharge: $\pm 4kV$					Criterion A



# CFM50S Series

## GENERAL SPECIFICATIONS

Radio-Frequency, Continuous Radiated Disturbance	IEC 61000-4-3:2020	Criterion A
Electrical Fast Transient (EFT)	IEC 61000-4-4:2012, $\pm 0.5kV$ , $\pm 1kV$ , $\pm 2kV$	Criterion A
Surge	IEC 61000-4-5:2014, L-N: $\pm 0.5kV$ , $\pm 1kV$ , L-E(Ground): $\pm 0.5kV$ , $\pm 1kV$ , $\pm 2kV$	Criterion A
Conducted Disturbances, Induced by RF Fields	IEC 61000-4-6:2013	Criterion A
Power Frequency Magnetic Field	IEC 61000-4-8:2009	Criterion A
Voltage Dips	IEC 61000-4-11:2004, Dip: 30% Reduction, Dip >95% Reduction	Criterion A
Voltage Interruptions	IEC 61000-4-11:2004, >95% Reduction	Criterion B
Application Note Link	<a href="#">CFM50S Series App Notes</a>	

## CHARACTERISTIC CURVE

### Power Derating Curve

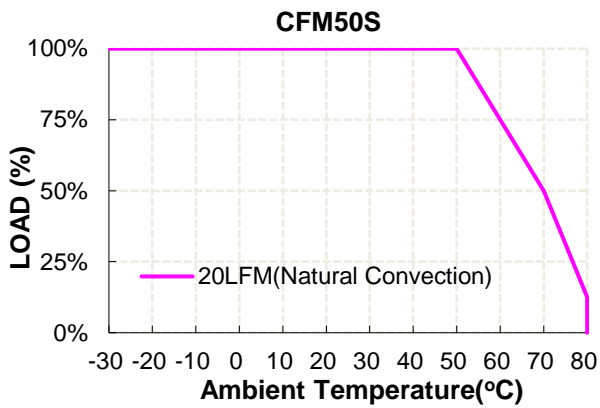

### Performance Data

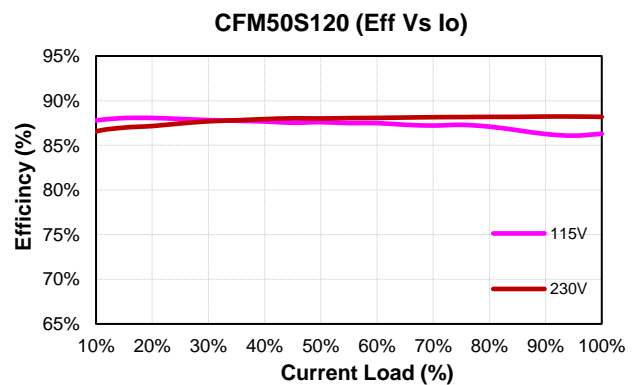
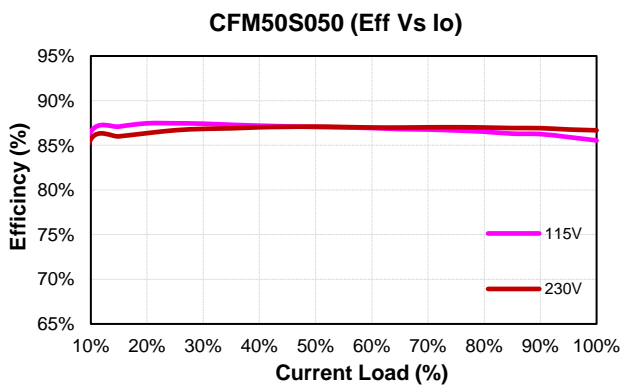



# CFM50S Series

CFM50S150 (Eff Vs Io)

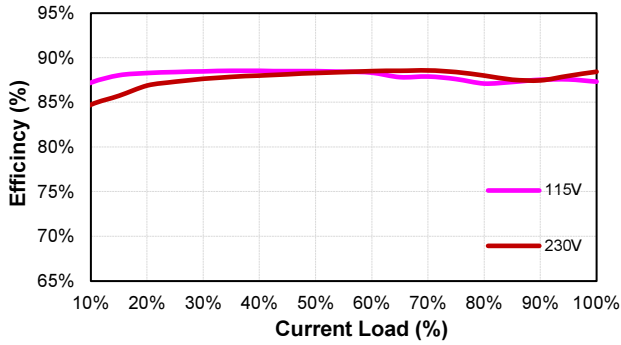

CFM50S240 (Eff Vs Io)

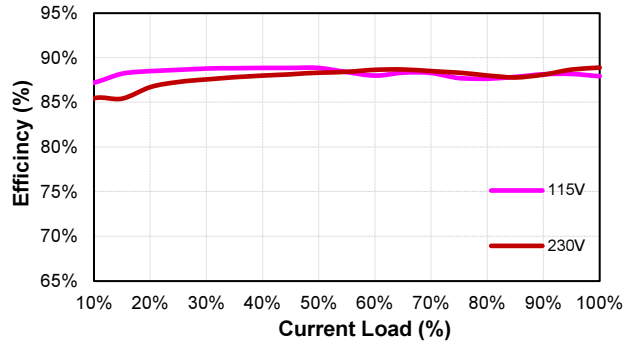

CFM50S360 (Eff Vs Io)

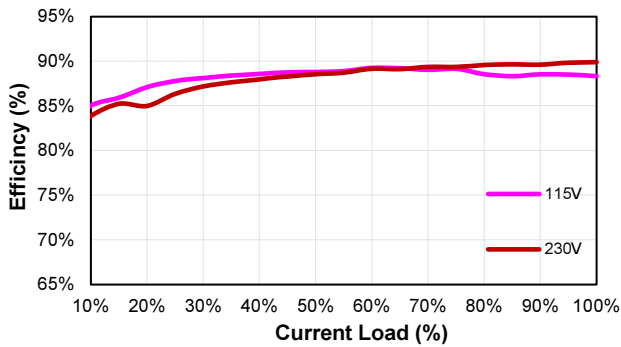

CFM50S480 (Eff Vs Io)

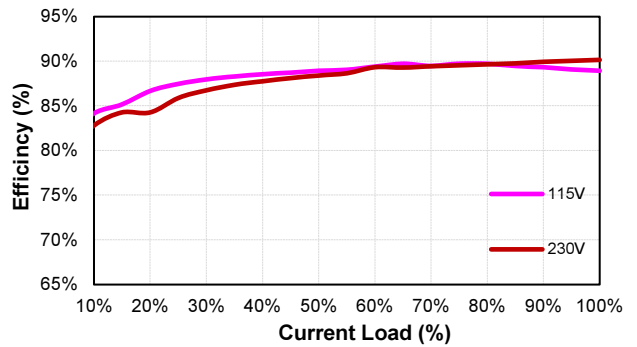

## MECHANICAL SPECIFICATION

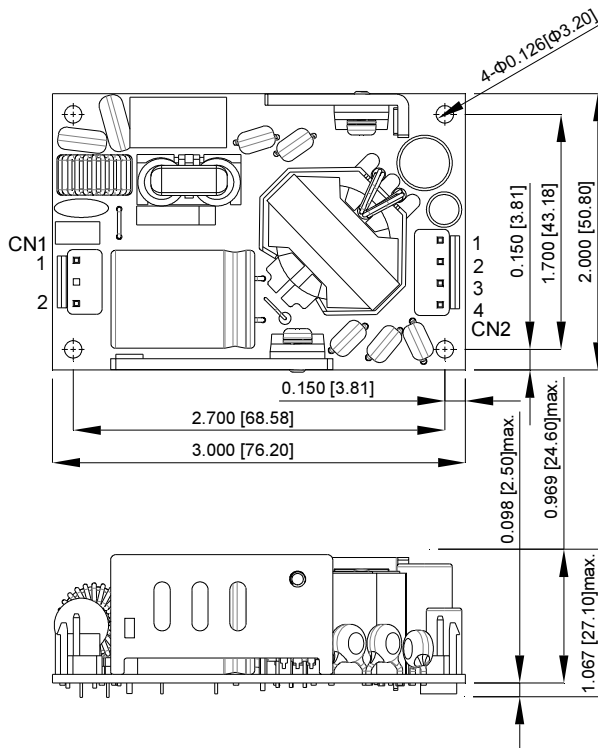

CN1

PIN CONNECTION	
PIN	Function
1	ACL
2	ACN

CN2

PIN CONNECTION	
PIN	Function
1	+Vout
2	+Vout
3	-Vout
4	-Vout

All Dimensions in Inches[mm]  
 Tolerance Inches : X.XXX=±0.02  
 Millimeters : X.XX=±0.5



## MECHANICAL SPECIFICATION

### CFM50SXXX-P

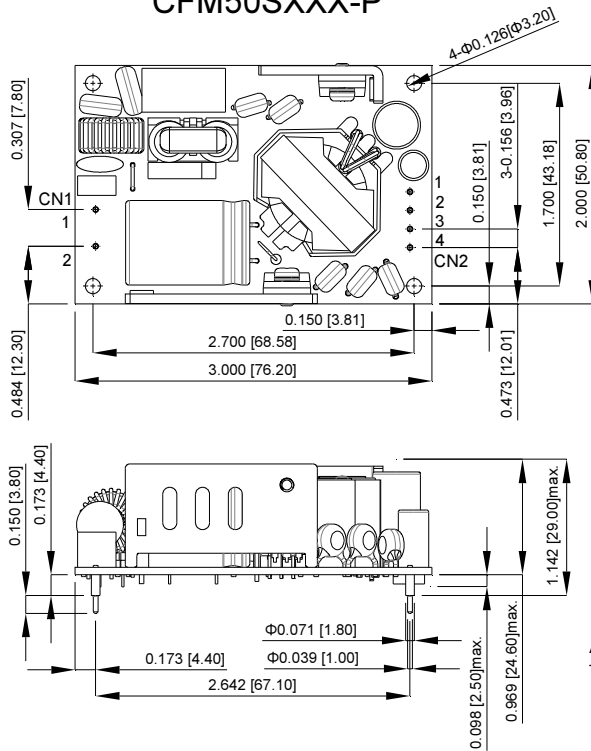

CN1

PIN CONNECTION	
PIN	Function
1	ACL
2	ACN

CN2

PIN CONNECTION	
PIN	Function
1	+Vout
2	+Vout
3	-Vout
4	-Vout

All Dimensions in Inches[mm]  
 Tolerance Inches : X.XXX=±0.02  
 Millimeters : X.XX=±0.5

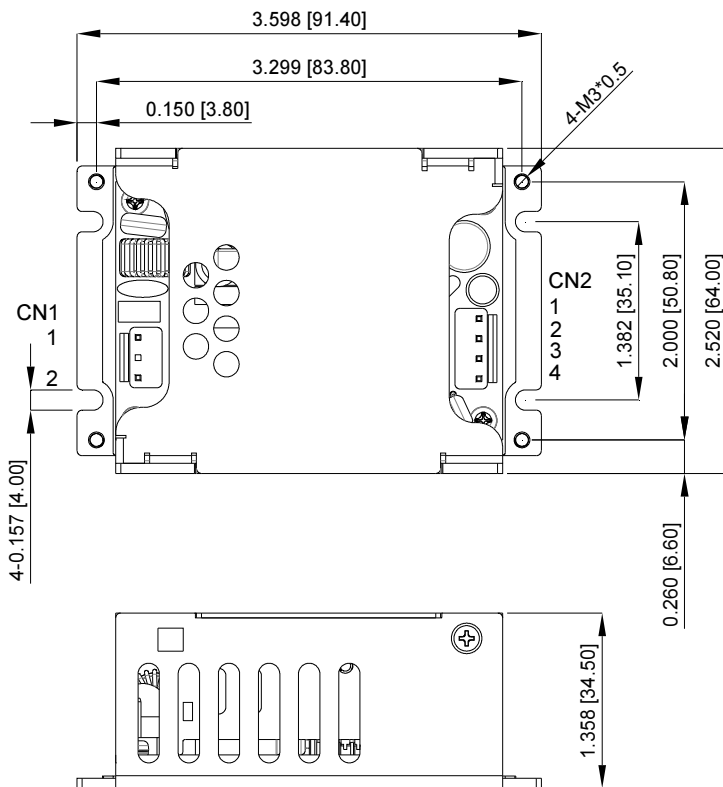

### CFM50SXXX-CA

All Dimensions in Inches[mm]  
 Tolerance Inches : X.XXX=±0.02  
 Millimeters : X.XX=±0.5

CN1

PIN CONNECTION	
PIN	Function
1	ACL
2	ACN

CN2

PIN CONNECTION	
PIN	Function
1	+Vout
2	+Vout
3	-Vout
4	-Vout