



electronicpowersolutions

CHB350 SERIES

231 - 350 WATT 2:1 INPUT

DC-DC CONVERTERS

SINGLE OUTPUT



FEATURES

- * 231-350W Isolated Output
- * Efficiency to 92.5%
- * Fixed Switching Frequency
- * Input Under Voltage Protection
- * Over Temperature Protection
- * Over Voltage/Current Protection
- * Remote On/Off
- * Industry Standard Half-Brick Package
- * Fully Isolated 1500VDC
- * UL60950-1 Approval
- * High Power Density 123W/in³



MODEL NUMBER	INPUT VOLTAGE	OUTPUT VOLTAGE	OUTPUT CURRENT		INPUT CURRENT		% EFF.	CAPACITOR LOAD MAX.
			MIN.	MAX.	NO LOAD	FULL LOAD		
CHB350-24S3V3□-X	18-36 VDC	3.3 VDC	0 mA	70 A	140 mA	10.94 A	88	10000μF
CHB350-24S05□-X	18-36 VDC	5 VDC	0 mA	70 A	260 mA	16.39 A	89	10000μF
CHB350-24S12□-X	18-36 VDC	12 VDC	0 mA	29.2 A	250 mA	16.13 A	90.5	10000μF
CHB350-24S24□-X	18-36 VDC	24 VDC	0 mA	14.6 A	60 mA	16.40 A	89	10000μF
CHB350-24S28□-X	18-36 VDC	28 VDC	0 mA	12.5 A	60 mA	16.11 A	90.5	100-7000μF ⁽³⁾
CHB350-24S48□-X	18-36 VDC	48 VDC	0 mA	7.3 A	60 mA	16.22 A	90	100-2200μF ⁽³⁾
CHB350-48S3V3□-X	36-75 VDC	3.3 VDC	0 mA	70 A	90 mA	5.41 A	89	10000μF
CHB350-48S05□-X	36-75 VDC	5 VDC	0 mA	70 A	130 mA	8.01 A	91	10000μF
CHB350-48S12□-X	36-75 VDC	12 VDC	0 mA	29.2 A	100 mA	7.89 A	92.5	10000μF
CHB350-48S24□-X	36-75 VDC	24 VDC	0 mA	14.6 A	60 mA	7.98 A	91.5	10000μF
CHB350-48S28□-X	36-75 VDC	28 VDC	0 mA	12.5 A	60 mA	7.93 A	92	100-7000μF ⁽³⁾
CHB350-48S48□-X	36-75 VDC	48 VDC	0 mA	7.3 A	60 mA	7.93 A	92	100-2200μF ⁽³⁾

NOTE:

1. □ = N or None, X can be L, I, C, IC
2. Nominal Input Voltage 24, 48VDC
3. The output terminal of 28Vout and 48Vout models required a minimum capacitor 100uF to maintain specified regulation.

SPECIFICATIONS

All Specifications Typical At Nominal Line, Full Load, and 25°C Unless Otherwise Noted

INPUT SPECIFICATIONS:

Input Voltage Range	24V	18-36V
	48V	36-75V
Input Surge Voltage (100ms max.)	24V	50Vdc max.
	48V	100Vdc max.
Under Voltage Lockout	24Vin power up	17V
	24Vin power down	16V
	48Vin power up	35V
	48Vin power down	33V

Positive Logic Remote On/Off (note4)

Logic Compatibility	Open Collector ref to -Input
Module on	>3.5Vdc to 75Vdc or Open Circuit
Module off	0 to < 1.2Vdc

Input Filter Pi Type

OUTPUT SPECIFICATIONS:

Voltage Accuracy	±1.0% max.
Transient Response: 25% Step Load Change	<500µs
External Trim Adj. Range (note7)	±10%
Ripple & Noise, 20MHz BW	
3.3V & 5V	40mV RMS max., 100mV pk-pk max.
12V	60mV RMS max., 120mV pk-pk max.
24V & 28V	100mV RMS max., 280mV pk-pk max.
48V	150mV RMS max., 480mV pk-pk max.
Temperature Coefficient	±0.03%/°C
Short Circuit Protection	Continuous
Line Regulation (note1)	±0.2% max.
Load Regulation (note2)	±0.2% max.
Over Voltage Protection Trip Range, % Vo nom.	115-140%
Current Limit	105%-140% Nominal Output
Start up time	175ms typ.

GENERAL SPECIFICATIONS:

Efficiency	See Table
Isolation Voltage	Input/Output 1500VDC min.
	Input/Case, Output/Case 1500VDC min.
Isolation Resistance	10 ⁷ ohm min.
Isolation Capacitance	2000pF typ.
Switching Frequency	3V3&5V 300KHz typ.
	12V&24V&28V&48V 330KHz typ.
Operating Case Temperature	-40°C to 100°C
Storage Temperature	-55°C to +105°C
Thermal Shutdown Case Temp	110°C typ.
Humidity	95% RH max. Non condensing
MTBF	MIL-HDBK-217F, GB, 25°C, Full Load 700Khrs typ.
Dimensions	Standard 2.28x2.40x0.52 inches (57.9x61.0x13.2 mm)
	Suffix "-L" 2.28x2.40x0.50inches (57.9x61.0x12.7mm)
Case Material	Aluminum Baseplate with Plastic Case
Weight	114g

NOTE:

1. Measured from high line to low line.
2. Measured from full load to zero load.
3. Output ripple and noise measured with 10uF tantalum (for 48Vout with 10uF aluminum) and 1uF ceramic capacitor across output.
4. Suffix "N" to the model number with negative logic remote on/off
 Module on 0 to < 1.2VDC
 Module off >3.5VDC to 75VDC or open circuit
5. Suffix "-C" to the model number with clear mounting Insert. (3.2mm DIA)
6. Suffix "-I" to the model number with thin input pin models (pin1 and pin4 =1.0mm).
7. Trim-up.....connect a resistor between the trim pin and +Sense
 Trim-down.....connect a resistor between the trim pin and -Sense
8. The input terminal recommend to parallel with 220uF for 48Vin and 470uF for 24Vin ESR<0.7Ω to reduce the input ripple voltage.

CASE HB

All Dimensions In Inches(mm)
 Tolerances Inches: X.XX=±0.02, X.XXX=±0.010
 Millimeters: X.X=±0.5, X.XX=±0.25

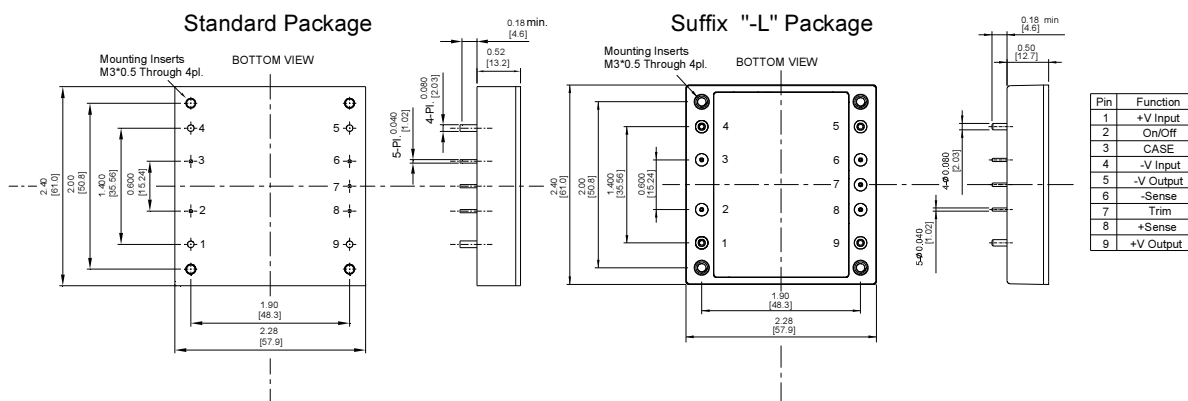

REMOTE ON/OFF CONTROL

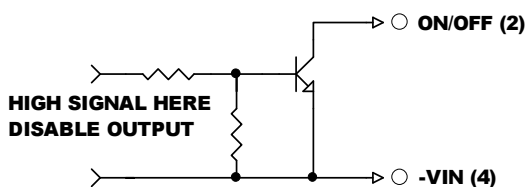

EXTERNAL OUTPUT TRIM

