

# EC6AW SERIES

## 8 WATT 4:1 INPUT

### DC-DC CONVERTERS



## FEATURES

- \* 8W Isolated Output
- \* DIP-24/SMD Metal Package
- \* Efficiency to 86%
- \* 4:1 Input Range
- \* Regulated Outputs
- \* Input Under-Voltage Protection
- \* Remote On/Off
- \* Continuous Short Circuit Protection
- \* Without Tantalum Capacitors Inside
- \* Safety Meets IEC/EN/UL 62368-1
- \* Meets EN50155 with External Circuits
- \* Shock & Vibration Meets EN50155 (EN61373)



MODEL NUMBER	INPUT VOLTAGE	OUTPUT VOLTAGE	OUTPUT CURRENT		INPUT CURRENT		% EFF.	CAPACITOR LOAD MAX.
			MIN.	MAX.	NO LOAD	FULL LOAD		
EC6AW-24S33	9-36 VDC	3.3 VDC	0 mA	2000 mA	10 mA	344 mA	80	2000uF
EC6AW-24S05	9-36 VDC	5 VDC	0 mA	1600 mA	10 mA	406 mA	82	1600uF
EC6AW-24S12	9-36 VDC	12 VDC	0 mA	666 mA	10 mA	392 mA	85	666uF
EC6AW-24S15	9-36 VDC	15 VDC	0 mA	530 mA	10 mA	390 mA	85	530uF
EC6AW-24D05	9-36 VDC	±5 VDC	0 mA	±800mA	10 mA	406 mA	82	800uF
EC6AW-24D12	9-36 VDC	±12 VDC	0 mA	±333mA	10 mA	392 mA	85	333uF
EC6AW-24D15	9-36 VDC	±15 VDC	0 mA	±265mA	10 mA	390 mA	85	265uF
EC6AW-48S33	18-75 VDC	3.3 VDC	0 mA	2000 mA	5 mA	172 mA	80	2000uF
EC6AW-48S05	18-75 VDC	5 VDC	0 mA	1600 mA	5 mA	201 mA	83	1600uF
EC6AW-48S12	18-75 VDC	12 VDC	0 mA	666 mA	5 mA	194 mA	86	666uF
EC6AW-48S15	18-75 VDC	15 VDC	0 mA	530 mA	5 mA	193 mA	86	530uF
EC6AW-48D05	18-75 VDC	±5 VDC	0 mA	±800mA	5 mA	201 mA	83	800uF
EC6AW-48D12	18-75 VDC	±12 VDC	0 mA	±333mA	5 mA	194 mA	86	333uF
EC6AW-48D15	18-75 VDC	±15 VDC	0 mA	±265mA	5 mA	193 mA	86	265uF

NOTE: 1. Nominal Input Voltage 24 or 48 VDC

# SPECIFICATIONS

All Specifications Typical at Nominal Line, Full Load, and 25°C Unless Otherwise Noted

## INPUT SPECIFICATIONS:

Input Voltage Range	24V	9 – 36V
	48V	18 – 75V
Input Surge Voltage (100ms max.)	24V	50Vdc max.
	48V	100Vdc max.
Under Voltage Lockout	24Vin power up	8.8V typ.
	24Vin power down	8.0V typ.
	48Vin power up	17V typ.
	48Vin power down	16V typ.
Input Filter		PI Type
Positive Logic Remote on/off Control (note3):		
Logic Compatibility		CMOS or Open Collector TTL, ref. to -Vin
Module On		>+3.5V to 36VDC or Open Circuit
Module Off		0 to <1.2VDC

## OUTPUT SPECIFICATIONS:

Voltage Accuracy	±1.5% max.
Voltage Balance (Dual)	±1.0% max.
Transient Response: 75% - 100% Step Load Change	
Error Band	±5% Vout Nominal, Recovery Time < 500us
Ripple & Noise, 20MHz BW (with 0.1uF MLCC)	
Vo=3.3 & 5V	75mV pk-pk max.
Vo=12 & 15V	100mV pk-pk max.
Temperature Coefficient	±0.03%/°C max.
Short Circuit Protection	Continuous
Line Regulation(note1)	Single/Dual ±0.5% max.
Load Regulation(note2)	Single ±0.5% max.
	Dual ±1.0% max.
Cross Regulation (Dual output) Load Cross Variation 25%/100%	±5% max.
Over Voltage Protection	Zener or TVS Clamp
Start up Time	3.5ms typ.

## GENERAL SPECIFICATIONS:

Efficiency	See Table
Isolation Voltage	1500 VDC min.
Isolation Resistance	10 <sup>9</sup> ohms min.
Isolation Capacitance	1000pF typ.
Switching Frequency	100KHz min.
Operating Ambient Temperature Range	-40°C to +85°C
Derating Above 71°C	Linearly to Zero Power at +100°C
Case Temperature (note5)	100°C
Cooling	Natural Convection
Storage Temperature Range	-55°C to +125°C
Humidity	95% RH max. Non Condensing
MTBF ... MIL-HDBK-217F, GB, 25°C, Full Load	Single 1500Khrs typ.
	Dual 1300Khrs typ.
EMC	Meets EN50155 (EN50121-3-2) with External Filter
Shock/Vibration	Meets EN50155 (EN61373)
Dimensions ... DIP	1.25x0.80x0.40 inches (31.8x20.3x10.2 mm)
	SMD 1.25x0.80x0.45 inches (31.8x20.3x11.4 mm)
Case Material	Black Coated Copper with Non-Conductive Base
Weight	18.4 g

## NOTE:

1. Measured from high line to low line.
2. Measured from full load to min. load.
3. Suffix "N" to the model number with negative logic remote on/off  
 Module on 0 to <1.2VDC  
 Module off >+3.5V to 36VDC or open circuit
4. Suffix "S" to the model number with SMD package.
5. Maximum case temperature under any operating condition should not be exceeded 100°C.

Typical Derating curve for Natural Convection

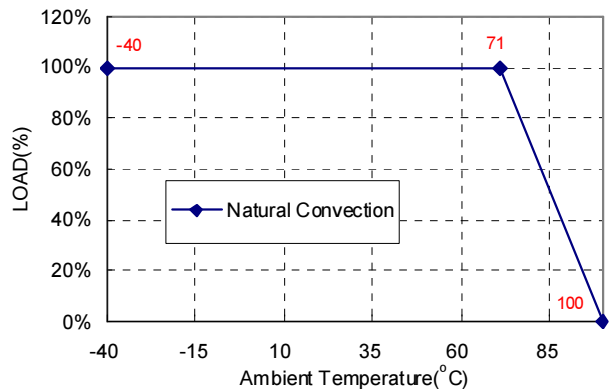

## CASE A Dimensions:

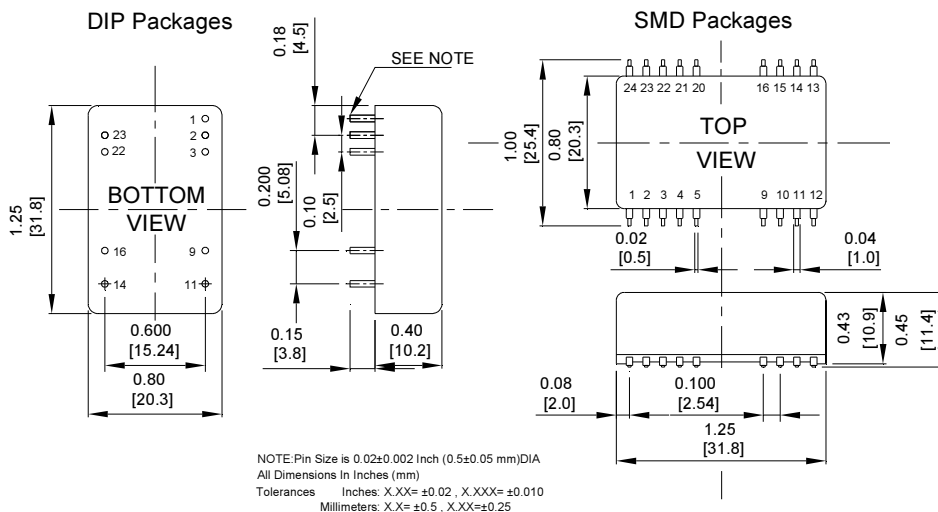

Pin	PIN CONNECTION			
	Single Output		Dual Output	
	DIP	SMD	DIP	SMD
1	Remote on/off	Remote on/off	Remote on/off	Remote on/off
2,3	-V Input		-V Input	
4,5	NP	NC	NP	NC
9	NP	NC	Common	
10	NP	NC	NP	NC
11	NC		-V Output	
12	NP	NC	NP	NC
13	NP	+V Output	NP	NC
14	+V Output		+V Output	
15	NP	-V Output	NP	NC
16	-V Output		Common	
20,21,24	NP	NC	NP	NC
22,23	+V Input		+V Input	

\* NC-NO CONNECTION WITH PIN  
 \* NP-NO PIN