



electronic powersolutions

LFM300M SERIES 300 WATT MEDICAL AC-DC POWER SUPPLY WITH PFC

Features

- Universal Input Range 85~264Vac
- High Efficiency up to 94%
- Class I & Class II
- 25.4mm Low Profile Package
- No Load Input Power Consumption<0.3W
- Approval Safety IEC/EN/UL 60601-1 2 MOPP
- Approval Safety IEC/EN/UL 62368-1
- Meets IEC/EN 60335-1
- Operating Altitude 5000m
- Continuous Short Circuit Protection
- Over Voltage Protection
- Over Temperature Protection
- High Power Density 37.1W/Inches³
- Active PFC Function



MODEL NUMBER	OUTPUT VOLTAGE	OUTPUT CURRENT			RIPPLE & NOISE NOTE1	VOLTAGE ACCURACY NOTE2	VOLTAGE ADJ. RANGE	LINE REGULATION NOTE3	LOAD REGULATION NOTE4	% EFF. (Typ.) NOTE5
		With Fan NOTE6	With Conduction Cooling NOTE7							
			Baseplate	Cover						
LFM300M120	12 V	25 A	14.2 A	20.83 A	150 mV	±1%	11.4-12.6 V	±0.3%	±0.5%	93%
LFM300M150	15 V	20 A	11.35 A	16.6 A	150 mV	±1%	14.25-15.75 V	±0.3%	±0.5%	93%
LFM300M240	24 V	12.5 A	7.1 A	10.4 A	240 mV	±1%	22.8-25.2 V	±0.3%	±0.5%	94%
LFM300M280	28 V	10.7 A	6.07 A	8.90 A	280 mV	±1%	26.6-29.4 V	±0.3%	±0.5%	94%
LFM300M300	30 V	10 A	5.67 A	8.33 A	300 mV	±1%	28.5-31.5 V	±0.3%	±0.5%	94%
LFM300M480	48 V	6.25 A	3.54 A	5.20 A	480 mV	±1%	45.6-50.4 V	±0.3%	±0.5%	94%
LFM300M540	54 V	5.56 A	3.15 A	4.63 A	540 mV	±1%	51.3-56.7 V	±0.3%	±0.5%	93%

Note:

1. Add a 0.1uF ceramic capacitor and a 10uF E.L. capacitor to output for ripple & noise measuring @20MHz BW.
2. Voltage accuracy is set at full load.
3. Line regulation is measured from 100Vac to 240Vac with full load.
4. Load regulation is measured from 10% to 100% full load.
5. Typical efficiency at 230 Vac and full load at 25°C.
6. Forced air convection with 14CFM above 115Vac.
7. With addition cooling conduction plate, 22.8 by 22.8 cm with min. 0.2 cm thick, as below.



LFM300M Series

PART NUMBER

Series	Number of Outputs	Nominal Output Voltage	Type	Mounting Inserts
LFM300	O	XXX	X	-YZ
LFM300	M : Medical	120 : 12V 150 : 15V 240 : 24V 280 : 28V 300 : 30V 480 : 48V 540 : 54V	B : With Baseplate C : With Cover	Blank : Through Hole C0 : Threaded Hole

Part Number Example:

LFM300M120C-C0: With Cover 300W, Single 12Vdc Output, Threaded Hole

LFM300M120B: With Baseplate 300W, Single 12Vdc Output, Through Hole



LFM300M Series

TECHNICAL SPECIFICATIONS

(All specifications are typical at nominal input, full load at 25°C unless otherwise noted.)

ABSOLUTE MAXIMUM RATINGS

PARAMETER	NOTES and CONDITIONS	Device	Min.	Typ.	Max.	Units
Input Voltage		All	85		264	V _{ac}
Operating Temperature	See derating curve	All	-40		80	°C
Operating Case Temperature	At the center of base plate (T _c = Case temperature)	All	-40		90	°C
Storage Temperature		All	-40		90	°C
Operating Altitude		All			5000	m

INPUT CHARACTERISTICS

PARAMETER	NOTES and CONDITIONS	Device	Min.	Typ.	Max.	Units
Operating Voltage Range		All	100		240	V _{ac}
Input Frequency Range		All	47		63	Hz
Maximum Input Current	100% Load, V _{in} =100V _{ac}	All			5.0	A
Leakage Current (Earth)		All			300	uA
Leakage Current (Touch)		All			100	uA
Inrush Current	V _{in} =240V _{ac} , Cold start @ 25°C	All			105	A
Power Factor	230V _{ac} @ Full load	All		0.92		

OUTPUT CHARACTERISTICS

PARAMETER	NOTES and CONDITIONS	Device	Min.	Typ.	Max.	Units
Output Voltage Set Point	V _{in} =Nominal V _{in} , I _o =I _o max., T _c =25°C	LFM300M120	11.88	12	12.12	V _{dc}
		LFM300M150	14.85	15	15.15	
		LFM300M240	23.76	24	24.24	
		LFM300M280	27.72	28	28.28	
		LFM300M300	29.7	30	30.3	
		LFM300M480	47.52	48	48.48	
Operating Output Current Range	V _{in} =85V _{ac} ~264V _{ac} , see derating curve	LFM300M120	0		25.0	A
		LFM300M150	0		20.0	
		LFM300M240	0		12.5	
		LFM300M280	0		10.7	
		LFM300M300	0		10.0	
		LFM300M480	0		6.25	
Holdup Time	V _{in} =115V _{ac}	All		12		ms
Output Voltage Regulation						
Load Regulation	10% Load to full load	All			±0.5	%
Line Regulation	V _{in} =High line to low line	All			±0.3	%
Output Voltage Adjustment	P _o ≤ max. rated power, I _o ≤ I _{o,max.}	All	-5		+5	%
Over Voltage Protection	Latch off (AC recycle to reset)	LFM300M120			16	V _{dc}
		LFM300M150			20	
		LFM300M240			32	
		LFM300M280			35	
		LFM300M300			36	
		LFM300M480			59	
Over Current Protection	Auto recovery (output is rated load)	All	110	120	150	%



LFM300M Series

PARAMETER	NOTES and CONDITIONS	Device	Min.	Typ.	Max.	Units
Short Circuit Protection	Auto recovery	All				
Over Temperature Protection	Auto recovery	All				
Output Ripple and Noise	1. Add a 0.1uF ceramic capacitor and a 10uF aluminum electrolytic capacitor to output 2. Oscilloscope is 20MHz band width 3. Ambient Temperature=25°C	LFM300M120			150	mV
		LFM300M150			150	
		LFM300M240			240	
		LFM300M280			280	
		LFM300M300			300	
		LFM300M480			480	
Load Capacitance	1. $V_{in}=115V_{ac}$ and $230V_{ac}$ 2. Output is max. load 3. Ambient temperature=25°C	LFM300M120			15400	uF
		LFM300M150			12200	
		LFM300M240			7800	
		LFM300M280			6600	
		LFM300M300			6200	
		LFM300M480			3870	
Efficiency	1. Input Voltage is $230V_{ac}$ 2. Output is rated load 3. Ambient temperature=25°C	LFM300M120		93		%
		LFM300M150		93		
		LFM300M240		94		
		LFM300M280		94		
		LFM300M300		94		
		LFM300M480		94		
LFM300M540		93				

ISOLATION CHARACTERISTICS

PARAMETER	NOTES and CONDITIONS	Device	Min.	Typ.	Max.	Units
Input to Output	1 Minute (without dielectric breakdown)	All			4250	V_{ac}
Input to Earth (Ground)	1 Minute (without dielectric breakdown)	All			2000	V_{ac}
Output to Earth (Ground)	1 Minute (without dielectric breakdown)	All			2000	V_{ac}
Isolation Resistance	Input to output	All	100			MΩ

FEATURE CHARACTERISTICS

PARAMETER	NOTES and CONDITIONS	Device	Min.	Typ.	Max.	Units
Switching Frequency	P_{out} =max. rated power	All		100		kHz

GENERAL SPECIFICATIONS

PARAMETER	NOTES and CONDITIONS	Device	Min.	Typ.	Max.	Units
MTBF	$I_o=100%$; $T_a=25^\circ C$ per MIL-HDBK-217F	All	500			k hours
	$I_o=100%$; $T_a=25^\circ C$ per Telcordia SR332		1690			
Life Time	@75% Load, 40°C	All	77			k hours
Humidity	Non-condensing	All			93	% RH
Shock	Meet MIL-STD-810F Table 516.5, Table 516.5-I 10ms, each axis 3 times($\pm X$ · $\pm Y$ · $\pm Z$ axis)	All		75		g
Vibration	Meet MIL-STD-810F Table 514.5C-VIII, 15~2000Hz, X · Y · Z axis, 1 hour (each axis),. Total 3 hrs.	All		4		g
Weight	Baseplate versions	LFM300MXXXB		200		grams
	Covered versions	LFM300MXXXC		280		
Dimensions	Baseplate versions	LFM300MXXXB	4.04x2.00x1.00 Inches (102.6x50.8x25.4 mm)			
	Covered versions	LFM300MXXXC	4.09x2.28x1.00 Inches (104.0x57.9x25.4 mm)			



GENERAL SPECIFICATIONS

Safety	Class I, Class II ANSI/AAMI ES 60601-1:2005 & A1:2012 & A2:2021 IEC 60601-1:2005/AMD1:2012 + AMD2:2020 EN 60601-1:2006/A1:2013 + A12:2014 + A2:2021	Ed. 3.2
	Class I, IEC/EN/UL 62368-1	Ed. 3.0
EMC Emission	EN 55011: 2016+A2: 2021, Class B, IEC/EN 61000-3-2: 2019+A1:2021, EN 61000-3-3: 2013+A2: 2021, 47 CFR FCC Part 18	
	EN 55032:2015+A11:2020 (Class B), EN 61000-6-4:2019, EN 61204-3:2018, EN 61000-3-2:2019+A1:2021, EN 61000-3-3:2013+A2:2021, 47 CFR FCC Part 15 Subpart B	
Conducted Disturbance	EN 55011: 2016+A2: 2021, EN 55032:2015+A11:2020 47, CFR FCC Part 18 & Part 15	Class B
Radiated Disturbance	EN 55011:2016+A2: 2021, CFR FCC Part 18 (Class II Only Meets Class A), EN 55032:2015+A11:2020 47,CFR FCC Part 15	Class B
Harmonic Current Emissions	IEC/EN 61000-3-2: 2019+A1:2021	Class A, D
Voltage Fluctuations & Flicker	EN 61000-3-3:2013+A2: 2021	Criterion A
EMC Immunity	EN 60601-1-2: 2015+A1:2021, IEC/EN 61000-4-2, 3, 4, 5, 6, 8, 11	Ed 4.1
	EN 55035:2017+A11:2020, EN 61000-6-2:2019, EN 61204-3:2018	
Electrostatic Discharge (ESD)	IEC 61000-4-2:2009 Air Discharge: $\pm 15\text{kV}$, Contact Discharge: $\pm 8\text{kV}$	Criterion A
Radio-Frequency, Continuous Radiated Disturbance	IEC/EN 61000-4-3: 2020	Criterion A
Electrical Fast Transient (EFT)	EN 61000-4-4:2012, $\pm 2\text{kV}$	Criterion A
Surge	EN 61000-4-5:2014+A1:2017, L-N: $\pm 2\text{kV}$, L-E (Ground): $\pm 4\text{kV}$	Criterion A
Conducted Disturbances, Induced by RF Fields	EN 61000-4-6: 2014+AC: 2015	Criterion A
Power Frequency Magnetic Field	EN 61000-4-8: 2010	Criterion A
Voltage Dips	IEC/EN 61000-4-11: 2020, Dip: 30% Reduction, Dip >95% Reduction	Criterion A
Voltage Interruptions	IEC/EN 61000-4-11: 2020, >95% reduction	Criterion B
Application Note Link	LFM300M Series App Notes	

CHARACTERISTIC CURVE

Power Derating Curve

Output Power vs Ambient Temperature

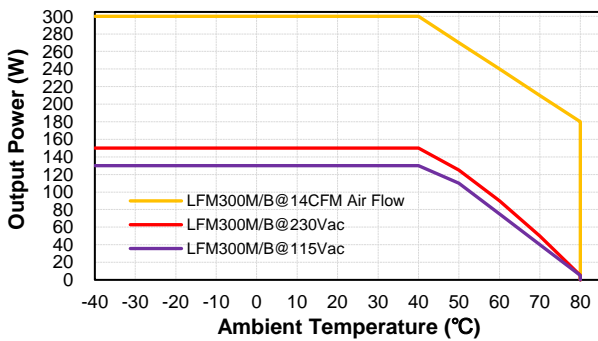

Output Power & Input Voltage

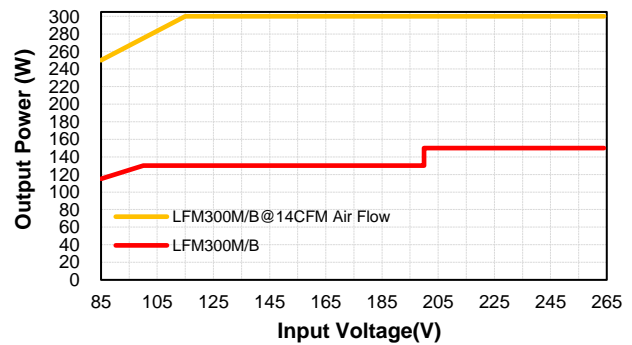

Output Power vs Ambient Temperature

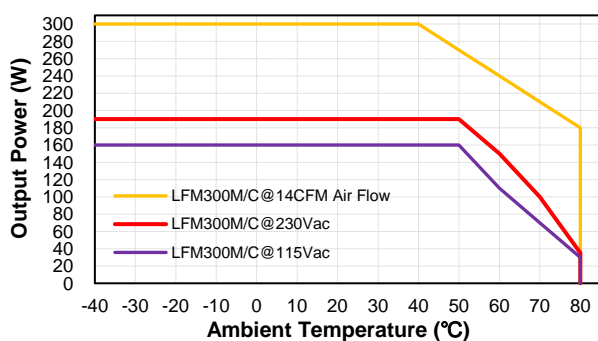

Output power & Input Voltage

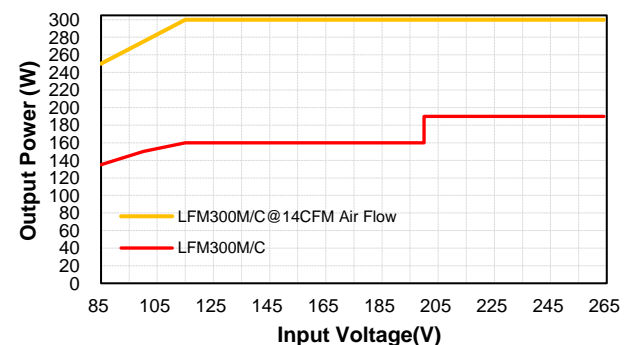

LFM300M Series

Conduction Convection with External Baseplate (22.8cmx22.8cmx0.2cm)

Output Power vs Ambient Temperature

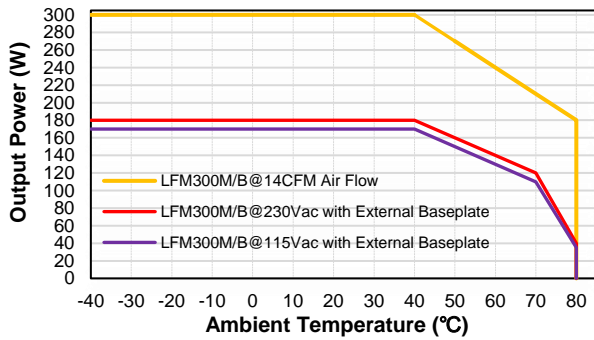

Output Power & Input Voltage

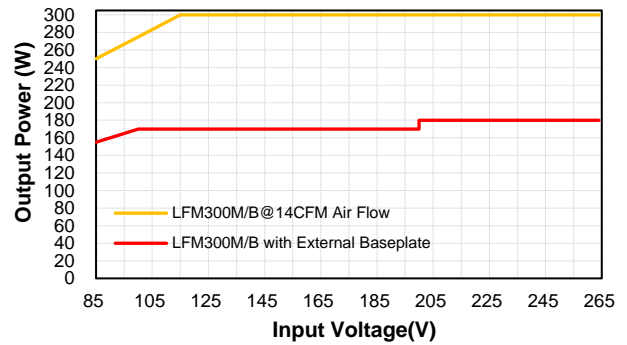

Output Power vs Ambient Temperature

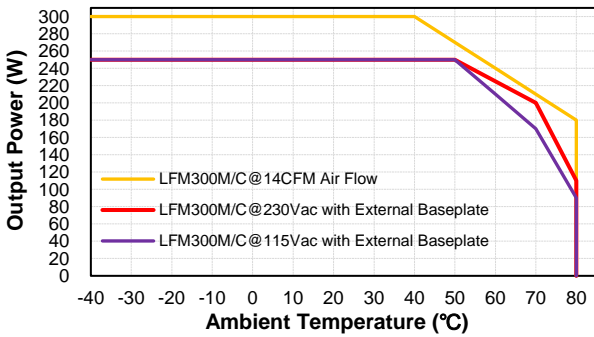

Output Power & Input Voltage

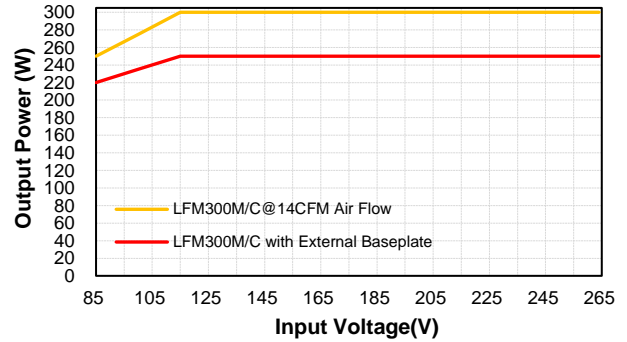

Output Power vs Case Temperature (Tc)

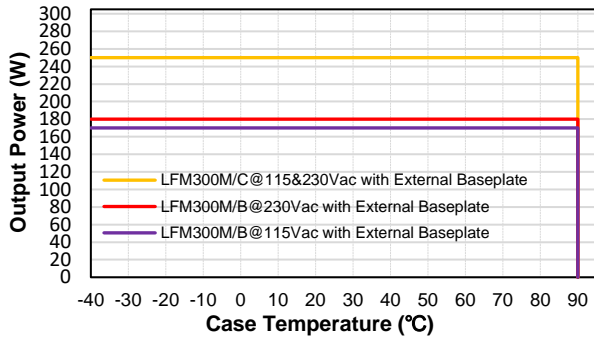

Performance Data

LFM300M120 (Eff Vs Io)

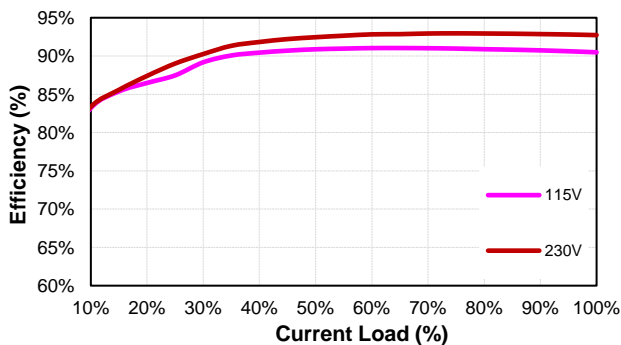

LFM300M150 (Eff Vs Io)

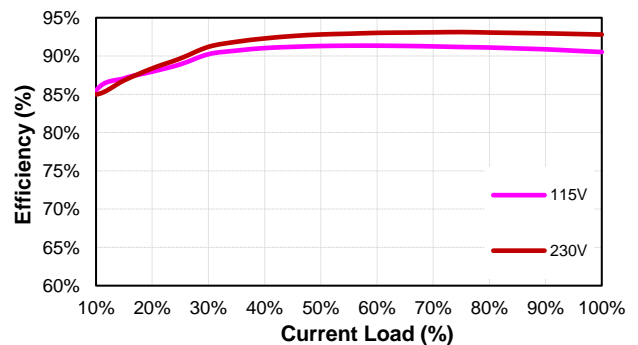



LFM300M Series

LFM300M240 (Eff Vs Io)

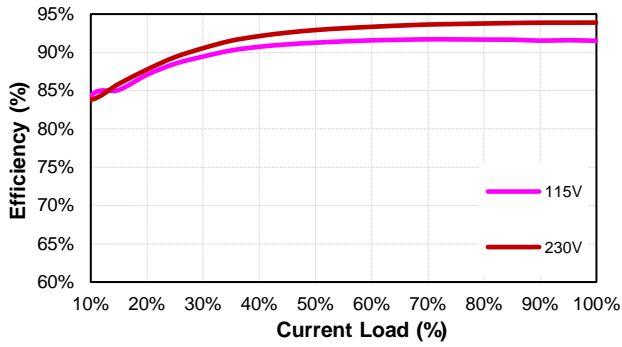

LFM300M280 (Eff Vs Io)

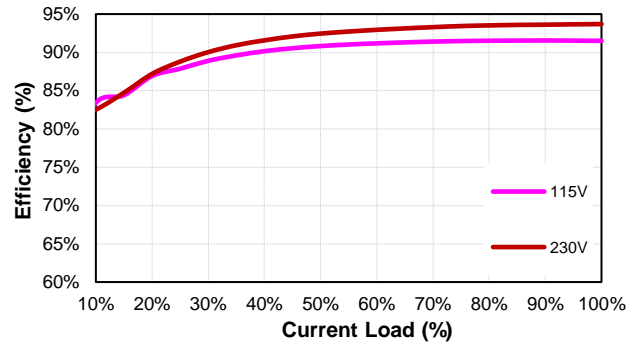

LFM300M300 (Eff Vs Io)

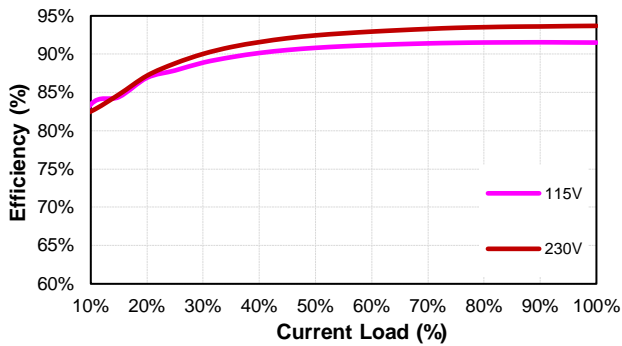

LFM300M480 (Eff Vs Io)

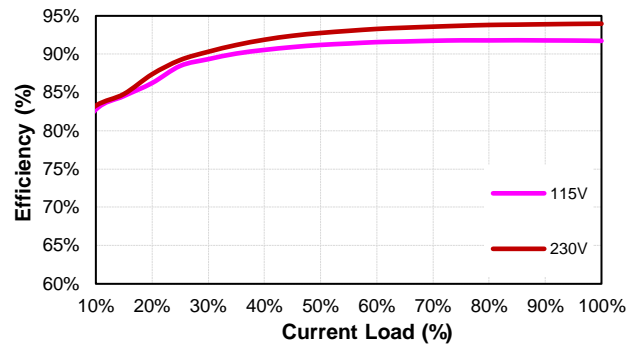

LFM300M540 (Eff Vs Io)

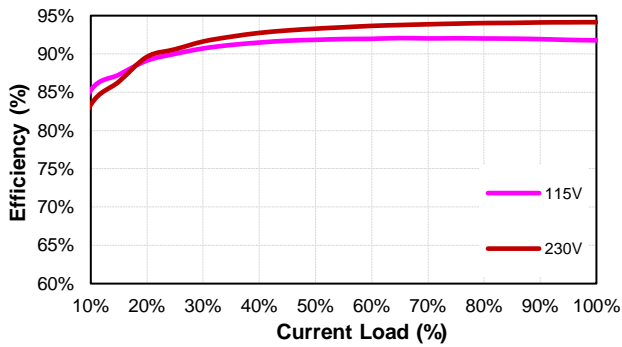

MECHANICAL SPECIFICATION

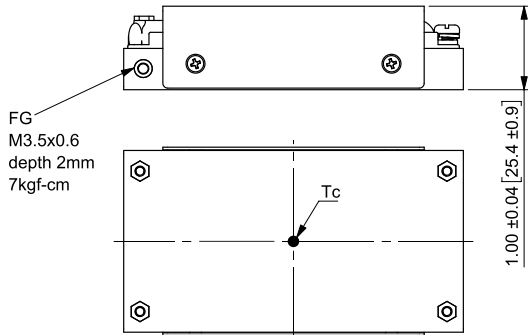
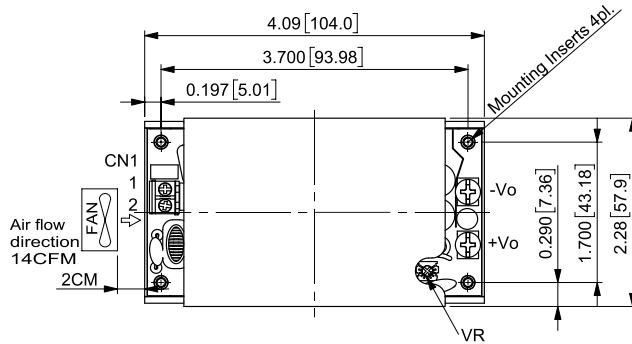

LFM300MXXXC LFM300MXXXC-C0

All Dimensions in Inches[mm]
Tolerance Inches: x.xx=±0.03, x.xxx=±0.020
Millimeters: x.x=±0.7, x.xx=±0.50

AC Input Connector(CN1):ECE ETB22

Pin	Function	Mating Wire Range
1	ACL	14~18 AWG
2	ACN	

DC Output Connector:KANG YANG PCB-58M4

Function	The screw locked torque
+Vo	M4 7kgf-cm
-Vo	

Mounting Inserts

Series	Option
Blank	Ø 3.2 Through depth 10.5mm
-C0	M3x0.5 Threaded depth 10.5mm

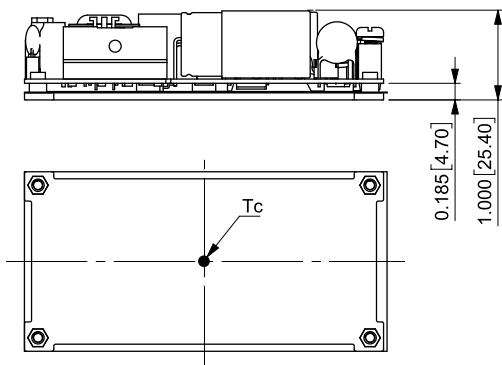
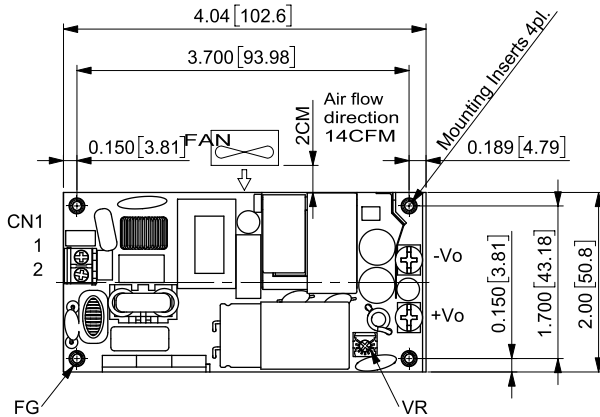

LFM300MXXXB LFM300MXXXB-C0

All Dimensions in Inches[mm]
Tolerance Inches: x.xx=±0.03, x.xxx=±0.020
Millimeters: x.x=±0.7, x.xx=±0.50

AC Input Connector(CN1):ECE ETB22

Pin	Function	Mating Wire Range
1	ACL	14~18 AWG
2	ACN	

DC Output Connector:KANG YANG PCB-58M4

Function	The screw locked torque
+Vo	M4 7kgf-cm
-Vo	

Mounting Inserts

Series	Option
Blank	Ø 3.2 Through depth 7.8mm
-C0	M3x0.5 Threaded depth 7.8mm

Specifications are subject to change without notice, E&OE. ALL PSU Terms & Conditions apply.

ALL PSU Ltd, Unit D6 Laser Quay, Culpeper Close, Medway City Estate,
Rochester, Kent, ME2 4HU, Tel : 01634 725527, Fax : 01634 739111
Email: sales@allpsu.co.uk, Web: www.allpsu.co.uk