



LFM420M SERIES 420 WATT MEDICAL AC-DC POWER SUPPLY WITH PFC

Features

- Universal Input Range 85~264Vac
- High Efficiency up to 94.5%
- Class I
- 25.4mm Low Profile Package
- No Load Input Power Consumption<0.5W
- No Load Input Power Consumption<0.6W for 54V
- Approval Safety IEC/EN/UL 60601-1 2 MOPP
- Approval Safety IEC/EN/UL 62368-1
- Meets IEC/EN60335-1
- Operating Altitude 5000m
- Continuous Short Circuit Protection
- Over Voltage Protection
- Over Temperature Protection
- High Power Density 28.0 W/Inches³
- Active PFC Function
- Constant Current



MODEL NUMBER	OUTPUT VOLTAGE	OUTPUT CURRENT			RIPPLE & NOISE NOTE1	VOLTAGE ACCURACY NOTE2	VOLTAGE ADJ. RANGE	LINE REGULATION NOTE3	LOAD REGULATION NOTE4	% EFF. (Typ.) NOTE5
		With Fan NOTE6	With Conduction Cooling NOTE7							
			Baseplate	Cover						
LFM420M120	12 V	35.00 A	26.25 A	29.17 A	120 mV	±1%	11.4-12.6 V	±0.5%	±1%	92.5%
LFM420M150	15 V	28.00 A	21.00 A	23.33 A	150 mV	±1%	14.25-15.75 V	±0.5%	±1%	93.0%
LFM420M240	24 V	17.50 A	13.13 A	14.58 A	240 mV	±1%	22.8-25.2 V	±0.5%	±1%	94.0%
LFM420M280	28 V	15.00 A	11.25 A	12.50 A	280 mV	±1%	28-29.4 V	±0.5%	±1%	94.0%
LFM420M300	30 V	14.00 A	10.50 A	11.67 A	300 mV	±1%	28.5-31.5 V	±0.5%	±1%	94.0%
LFM420M360	36 V	11.67 A	8.75 A	9.72 A	360 mV	±1%	34.2-37.8 V	±0.5%	±1%	94.0%
LFM420M480	48 V	8.75 A	6.56 A	7.29 A	480 mV	±1%	45.6-50.4 V	±0.5%	±1%	94.0%
LFM420M540	54 V	7.78 A	5.83 A	6.48 A	540 mV	±1%	51.3-55.0 V	±0.5%	±1%	94.5%

Note:

1. Add a 0.1uF ceramic capacitor and a 10uF E.L. capacitor to output for ripple & noise measuring @20MHz BW.
2. Voltage accuracy is set at full load and 25°C Ta.
3. Line regulation is measured from high line to low line with rated load.
4. Load regulation is measured from full load to 10% rated load.
5. Typical efficiency at 230 Vac and full load at 25°C.
6. Forced air convection with 21.9CFM above 100V_{ac}.
7. Conduction convection with external baseplate,24.8*48.0cm with min.0.12cm thick @115V_{ac}.



LFM420M Series

PART NUMBER

Series	Number of Outputs	Nominal Output Voltage	Type	Mounting Inserts
LFM420	O	XXX	X	-YZ
LFM420	M : Medical	120 : 12V 150 : 15V 240 : 24V 280 : 28V 300 : 30V 360 : 36V 480 : 48V 540 : 54V	B : With Baseplate C : With Cover	Blank: Through Hole C0: Threaded Hole

Part Number Example:

LFM420M120C: With Cover, 420W, 12Vdc Output, Through Hole



TECHNICAL SPECIFICATIONS

(All specifications are typical at nominal input, full load at 25°C unless otherwise noted.)

ABSOLUTE MAXIMUM RATINGS

PARAMETER	NOTES and CONDITIONS	Device	Min.	Typ.	Max.	Units
Input Voltage	Safety approvals only to the AC input	All	85		264	V _{ac}
	No safety approvals		120		370	V _{dc}
Operating Temperature	See derating curve	All	-40		80	°C
Operating Case Temperature	At the center of base plate (T _c = Case temperature)	All	-40		85	°C
Storage Temperature		All	-40		85	°C
Operating Altitude		All			5000	m

INPUT CHARACTERISTICS

PARAMETER	NOTES and CONDITIONS	Device	Min.	Typ.	Max.	Units
Operating Voltage Range		All	100		240	V _{ac}
Input Frequency Range		All	47		63	Hz
Maximum Input Current	100% Load, V _{in} =100Vac	All			6	A
Leakage Current (Earth)		All			300	uA
Leakage Current (Touch)		All			100	uA
Inrush Current	V _{in} =240V _{ac} , Cold start at 25°C	All		30		A
Under Voltage Protection		All	65		75	V _{ac}
Power Factor	230V _{ac} @ Full load	All		0.95		

OUTPUT CHARACTERISTICS

PARAMETER	NOTES and CONDITIONS	Device	Min.	Typ.	Max.	Units
Output Voltage Set Point	V _{in} =Nominal V _{in} , I _o =I _o max., T _c =25°C	LFM420M120	11.88	12	12.12	V _{dc}
		LFM420M150	14.85	15	15.15	
		LFM420M240	23.76	24	24.24	
		LFM420M280	27.72	28	28.28	
		LFM420M300	29.70	30	30.30	
		LFM420M360	35.64	36	36.36	
		LFM420M480	47.52	48	48.48	
		LFM420M540	53.46	54	54.54	
Operating Output Current Range	V _{in} =85V _{ac} ~264V _{ac} , see derating curve	LFM420M120			35.00A	A
		LFM420M150			28.00A	
		LFM420M240			17.50A	
		LFM420M280			15.00A	
		LFM420M300			14.00A	
		LFM420M360			11.67A	
		LFM420M480			8.75A	
		LFM420M540			7.78A	
Holdup Time	V _{in} =115V _{ac} Load: 350W, ambient temperature=25°C	All		12		ms
	V _{in} =115V _{ac} Load: 420W, ambient temperature=25°C			8		
Output Voltage Regulation						
Load Regulation	10% Load to full load	All			±1.0	%
Line Regulation	V _{in} =High line to low line	All			±0.5	%
Output Voltage adjustment	P _o ≤ max. rated power, I _o ≤ I _o max.	LFM420M280	0		+5	%
	P _o ≤ max. rated power, I _o ≤ I _o max.	LFM420M540	-5		+2	%
	P _o ≤ max. rated power, I _o ≤ I _o max.	Others	-5		+5	%



LFM420M Series

PARAMETER	NOTES and CONDITIONS	Device	Min.	Typ.	Max.	Units
Over Voltage Protection	Latch off (reset after about one minute after the input is turned off)	LFM420M120		16		V _{dc}
		LFM420M150		20		
		LFM420M240		30		
		LFM420M280		35		
		LFM420M300		35		
		LFM420M360		50		
		LFM420M480		63		
		LFM420M540		63		
Over Current Protection	Constant current, auto recovery (see application note)	All	110		170	%
Short Circuit Protection	Auto Recovery	All				
Over Temperature Protection	Auto Recovery If conduction convection with external baseplate is used or the recommended temperature curve is exceeded, the T _c temperature must be maintained <85°C	All				
Output Ripple and Noise	1. Add a 0.1uF ceramic capacitor and a 10uF aluminum electrolytic capacitor to output 2. Oscilloscope is 20MHz Band Width 3. Ambient Temperature=25°C	LFM420M120			120	mV
		LFM420M150			150	
		LFM420M240			240	
		LFM420M280			280	
		LFM420M300			300	
		LFM420M360			360	
		LFM420M480			480	
		LFM420M540			540	
Load Capacitance	1. V _{in} =115V _{ac} and 230V _{ac} 2. Output is max. load 3. Ambient temperature=25°C	LFM420M120			29100	uF
		LFM420M150			23300	
		LFM420M240			14500	
		LFM420M280			12500	
		LFM420M300			11600	
		LFM420M360			9700	
		LFM420M480			7200	
		LFM420M540			6400	
Efficiency	1. Input Voltage is 230V _{ac} 2. Output is rated load 3. Ambient temperature=25°C	LFM420M120		92.5%		%
		LFM420M150		93.0%		
		LFM420M240		94.0%		
		LFM420M280		94.0%		
		LFM420M300		94.0%		
		LFM420M360		94.0%		
		LFM420M480		94.0%		
		LFM420M540		94.5%		

ISOLATION CHARACTERISTICS

PARAMETER	NOTES and CONDITIONS	Device	Min.	Typ.	Max.	Units
Input to Output	1 Minute (without dielectric breakdown)	All			4250	V _{ac}
Input to Earth (Ground)	1 Minute (without dielectric breakdown)	All			2000	V _{ac}
Output to Earth (Ground)	1 Minute (without dielectric breakdown)	All			2000	V _{ac}
Isolation Resistance	Input to output	All	100			MΩ

FEATURE CHARACTERISTICS

PARAMETER	NOTES and CONDITIONS	Device	Min.	Typ.	Max.	Units
Switching Frequency	P _{out} =max. rated power	All		65		kHz



GENERAL SPECIFICATIONS

PARAMETER	NOTES and CONDITIONS	Device	Min.	Typ.	Max.	Units
MTBF	I _o =100%; T _a =25°C per MIL-HDBK-217F I _o =100%, T _a =25°C, Telcordia SR332	All	1600	400		K hours
Life Time	@75% Load, 40°C	All	26			k hours
Humidity	Non-condensing	All			93	% RH
Shock	Meet MIL-STD-810F Table 516.5, Table 516.5-1 10ms, each axis 3 times(±X · ±Y · ±Z axis)	All		75		g
Vibration	Meet MIL-STD-810F Table 514.5C-VIII, 15~2000Hz, X · Y · Z axis, 1 hour (each axis),. Total 3 hrs.	All		4		g
Weight	Baseplate versions Covered versions	All		350 470		g
Dimensions	Baseplate versions Covered versions	All	5.00x3.00x1.00 Inches (127x76.2x25.40mm) 5.09x3.29x1.00 Inches (129.4x83.5x25.4mm)			
Safety	Class I, ANSI/AAMI ES 60601-1:2005 & A1:2012 & A2:2021 IEC 60601-1:2005/AMD1:2012 + AMD2:2020, EN 60601-1:2006/A1:2013 + A12:2014 + A2:2021					Ed. 3.2
	Class I, IEC/EN/UL 62368-1					Ed. 3.0
EMC Emission	EN 55011: 2016+A2: 2021, Class B, IEC/EN 61000-3-2: 2019+A1:2021, EN 61000-3-3: 2013+A2: 2021, 47 CFR FCC Part 18 EN 55032:2015+A11:2020 (Class B), EN 61000-6-3:2021, EN 61000-6-4:2019, EN 61204-3:2018, EN 61000-3-2:2019+A1:2021, EN 61000-3-3:2013+A2:2021, 47 CFR FCC Part 15 Subpart B					
Conducted Disturbance	EN 55011: 2016+A2: 2021, EN 55032:2015+A11:2020 47, CFR FCC Part 18 & Part 15					Class B
Radiated Disturbance	EN 55011: 2016+A2: 2021, EN 55032:2015+A11:2020 47, CFR FCC Part 18 & Part 15					Class B
Harmonic Current Emissions	IEC/EN 61000-3-2: 2019+A1:2021					Class A,C,D
Voltage Fluctuations & Flicker	EN 61000-3-3:2013+A2: 2021					Criterion A
EMC Immunity	EN 60601-1-2: 2015+A1:2021, IEC/EN 61000-4-2, 3, 4, 5, 6, 8, 11 EN 55035:2017+A11:2020, EN 61000-6-1:2019+CRGD:2019, EN 61000-6-2:2019, EN 61204-3:2018					Ed 4.1
Electrostatic Discharge (ESD)	IEC 61000-4-2:2009 Air Discharge: ±15kV, Contact Discharge: ±8kV					Criterion A
Radio-Frequency, Continuous Radiated Disturbance	IEC/EN 61000-4-3: 2020					Criterion A
Electrical Fast Transient (EFT)	EN 61000-4-4:2012, ±2kV					Criterion A
Surge	IEC 61000-4-5:2014+A1:2017, Line-Line: ±2kV, Line-Earth (Ground): ±4kV					Criterion A
Conducted Disturbances, Induced by RF Fields	EN 61000-4-6: 2014+AC: 2015					Criterion A
Power Frequency Magnetic Field	EN 61000-4-8: 2010					Criterion A
Voltage Dips	IEC/EN 61000-4-11: 2020, Dip: 30% Reduction, Dip >95% Reduction					Criterion A
Voltage Interruptions	IEC/EN 61000-4-11: 2020, >95% reduction					Criterion B
Application Note Link						LFM420M Series App Notes



CHARACTERISTIC CURVE

Power Derating Curve

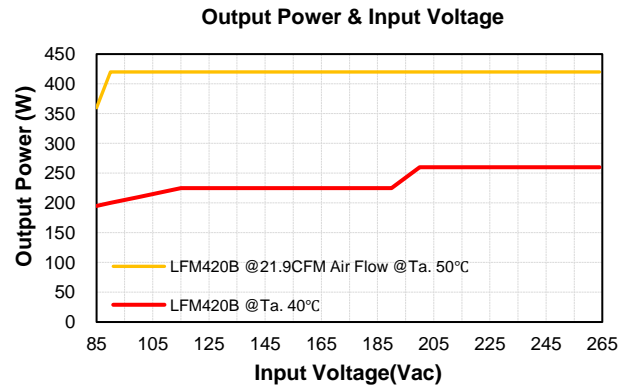
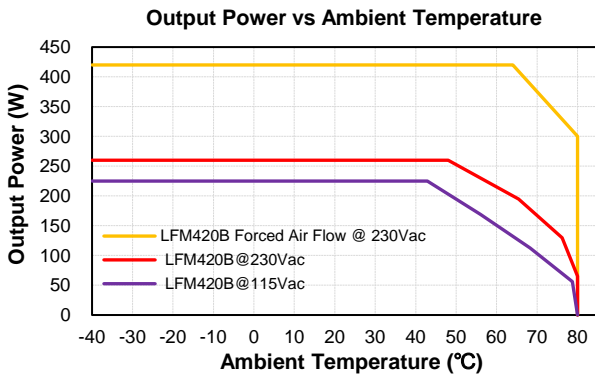
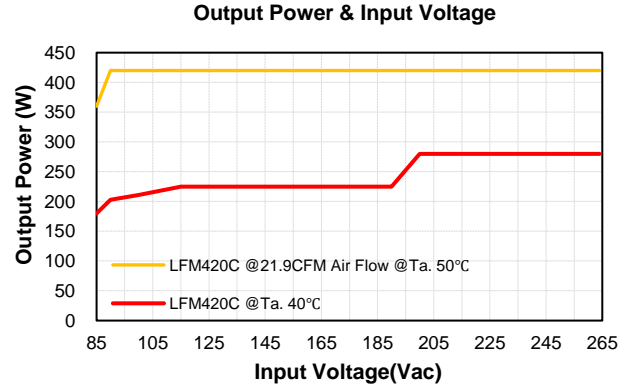
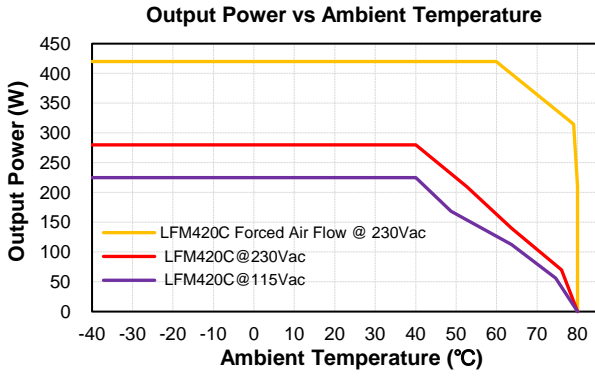

Conduction Convection with External Baseplate (24.8cmx48cmx0.12cm)

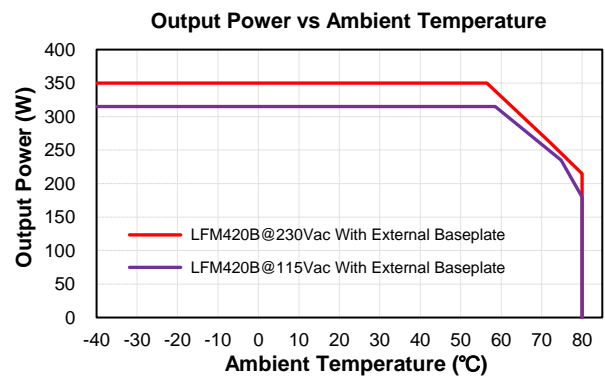
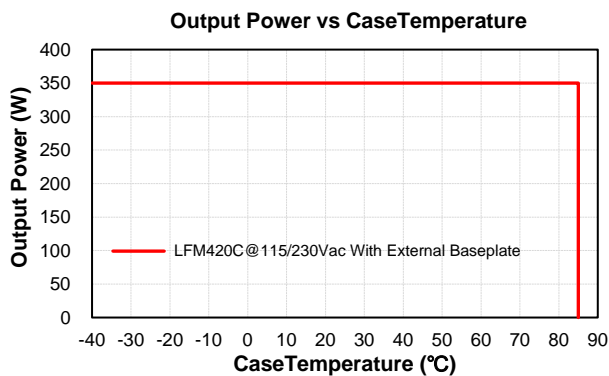
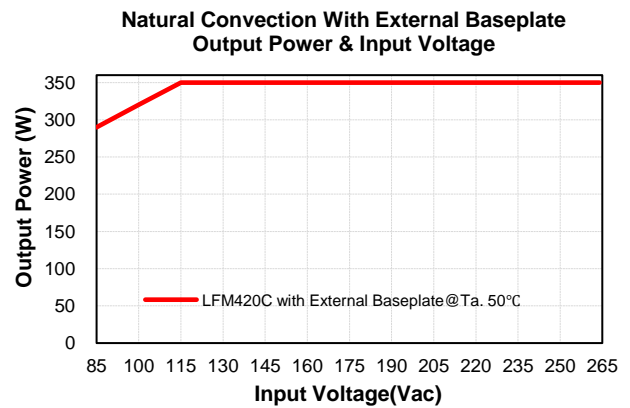
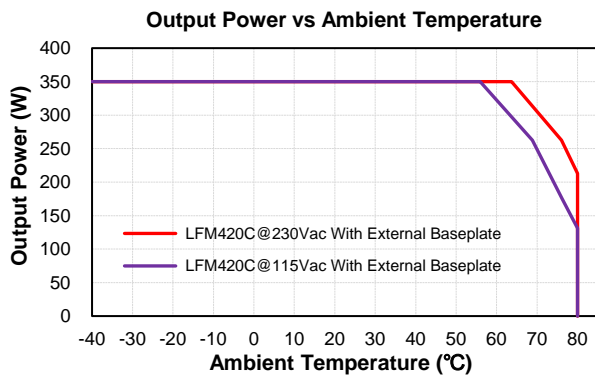



LFM420M Series

Natural Convection With External Baseplate Output Power & Input Voltage

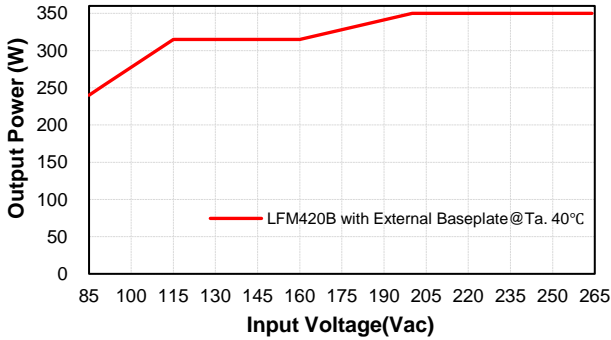

Output Power vs CaseTemperature

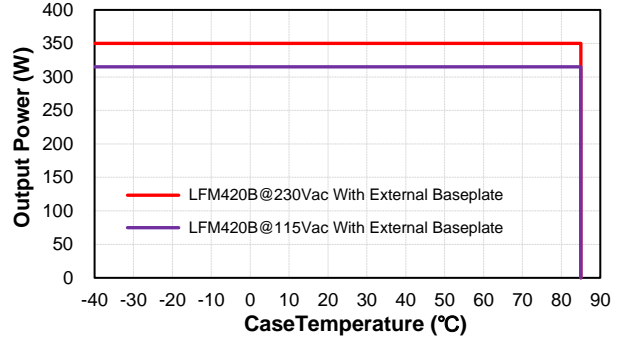

Performance Data

LFM420M120 (Eff Vs Io)

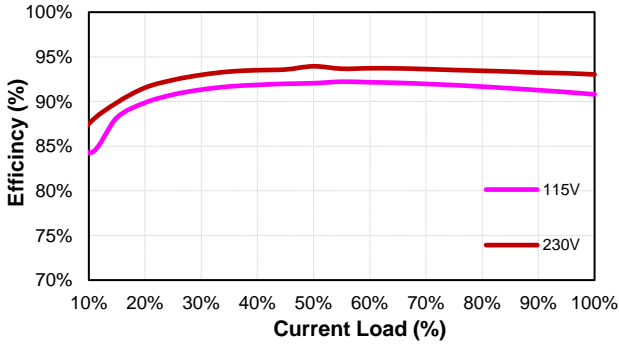

LFM420M150 (Eff Vs Io)

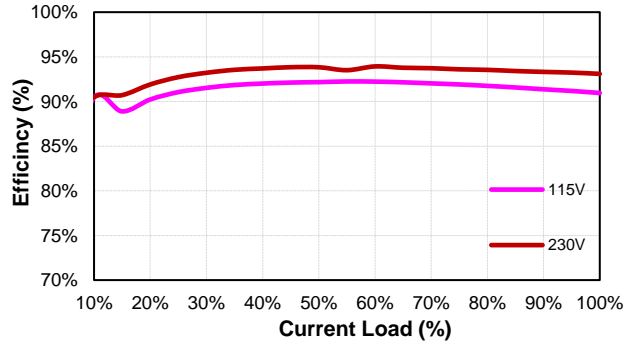

LFM420M240 (Eff Vs Io)

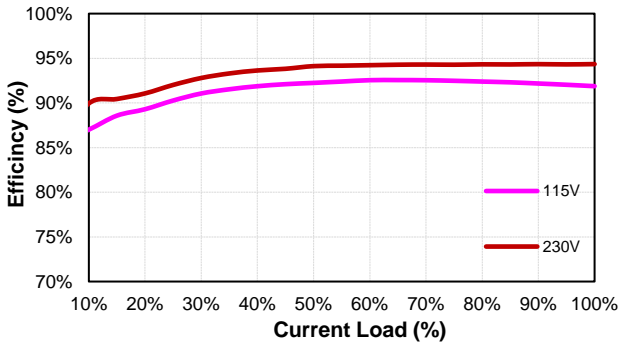

LFM420M280 (Eff Vs Io)

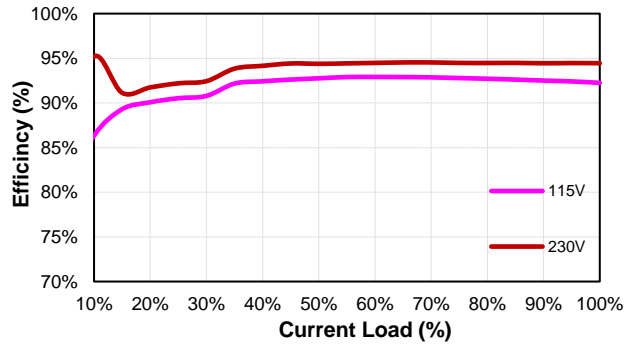

LFM420M300 (Eff Vs Io)

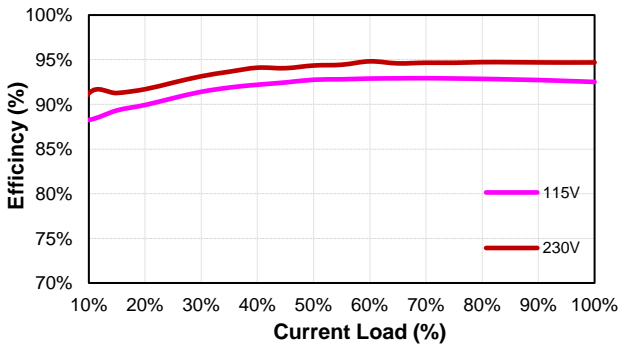

LFM420M360 (Eff Vs Io)

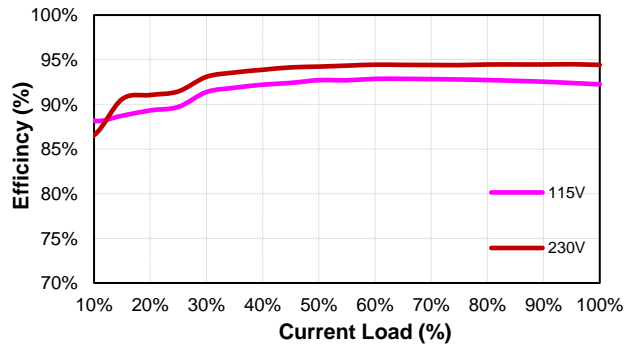



LFM420M Series

LFM420M480 (Eff Vs Io)

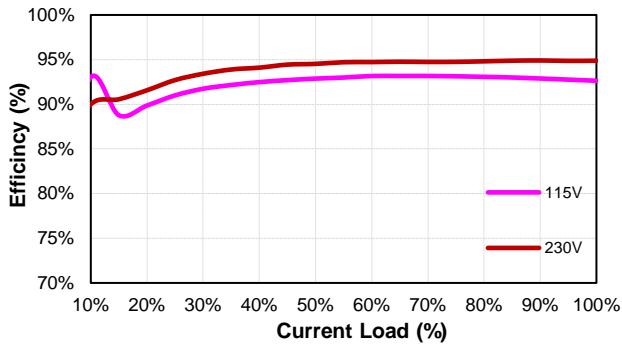

LFM420M540 (Eff Vs Io)

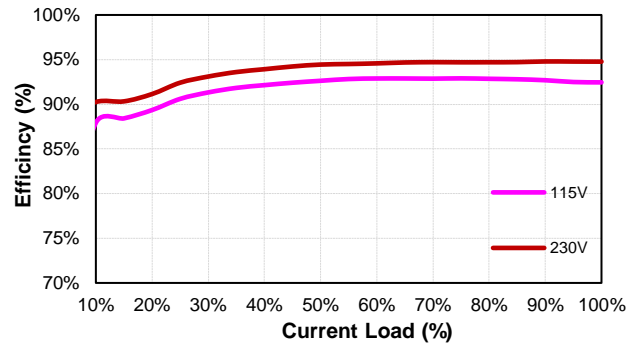

MECHANICAL SPECIFICATION

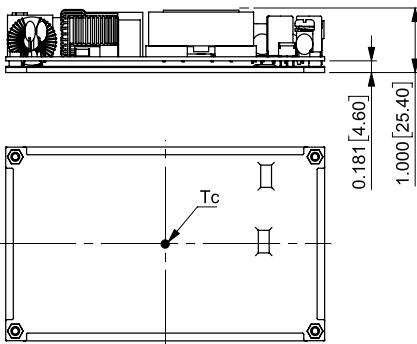
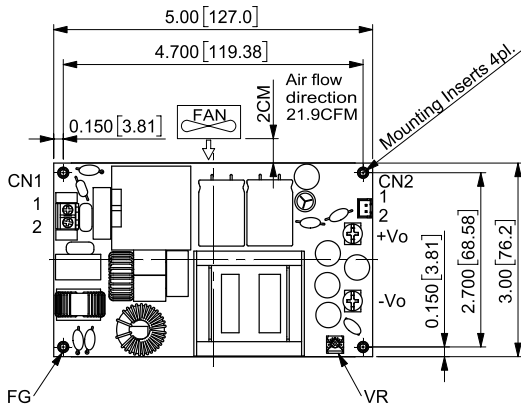
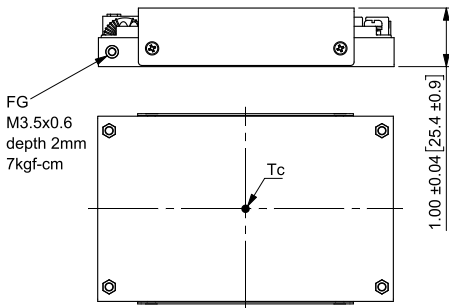
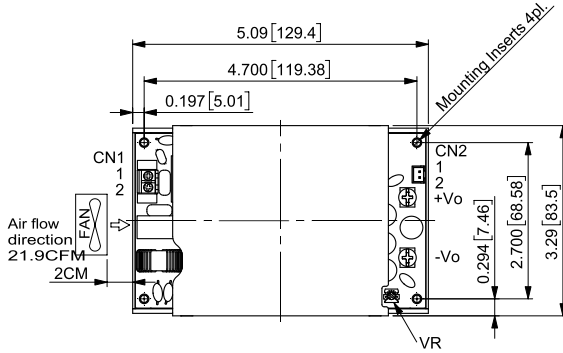

LFM420MXXXC LFM420MXXXC-C0

All Dimensions in Inches[mm]
Tolerance Inches: x.xx=±0.03, x.xxx=±0.020
Millimeters: x.x=±0.7, x.xx=±0.50

AC Input Connector(CN1):ECE ETB22

Pin	Function	Mating Wire Range
1	ACL	14~18 AWG
2	ACN	

DC Output Connector(CN2):TKP 8822-02-NHB or equivalent

Pin	Function	Mating Housing	Terminal
1	Rs+	JST XHP-2 or equivalent	JST SXH-001T-P0.6N or equivalent
2	Rs-		

DC Output Connector:KANG YANG PCB-58M4

Function	The screw locked torque
+Vo	M4 7kgf-cm
-Vo	

Mounting Inserts

Series	Option
Blank	∅3.2 Through depth 10.5mm
-C0	M3x0.5 Threaded depth 10.5mm

LFM420MXXXB LFM420MXXXB-C0

All Dimensions in Inches[mm]
Tolerance Inches: x.xx=±0.03, x.xxx=±0.020
Millimeters: x.x=±0.7, x.xx=±0.50

AC Input Connector(CN1):ECE ETB22

Pin	Function	Mating Wire Range
1	ACL	14~18 AWG
2	ACN	

DC Output Connector(CN2):TKP 8822-02-NHB or equivalent

Pin	Function	Mating Housing	Terminal
1	Rs+	JST XHP-2 or equivalent	JST SXH-001T-P0.6N or equivalent
2	Rs-		

DC Output Connector:KANG YANG PCB-58M4

Function	The screw locked torque
+Vo	M4 7kgf-cm
-Vo	

Mounting Inserts

Series	Option
Blank	∅3.2 Through depth 8.1mm
-C0	M3x0.5 Threaded depth 8.1mm

Specifications are subject to change without notice, E&OE. ALL PSU Terms & Conditions apply.

ALL PSU Ltd, Unit D6 Laser Quay, Culpeper Close, Medway City Estate,
Rochester, Kent, ME2 4HU, Tel : 01634 725527, Fax : 01634 739111
Email: sales@allpsu.co.uk, Web: www.allpsu.co.uk